

Article Code	m <sup>3</sup> /h	Hz	Power(W)	dB	Volts	Max. temp.	Weight
PK355/400-EC	4800	50/60	550W	78*	230	45°C	18,50 Kg

\*maximal noise ratio from the motor without housing

#### Features:

- ZIEHL-ABEGG motor
- Low noise emissions
- Non-stop operation, over 80.000 hours
- Galvanized steel housing
- Controllable with 0-10V signal
- Junction box with Schuko power cable

#### Safety Information

This machinery must not be put in operation until prior to reading mounting instructions and safety information. All fans are intended for transportation of air in air handling systems. If installed in non-heated rooms, the fan casing has to be insulated in order to avoid condensation. They are meant to be used after building them into machines or duct systems or after contact protection grid have been installed. (EN ISO 13857). Fans with duct connections must be connected to ducts on both sides (inlet/outlet). When there is a risk of water entering the motor, via the ducts, external protection is required. No moving parts shall be accessible after installation. The fans are not to be used in hazardous environments or connected to flue ducts. The fans must not be installed outdoors, (with exception of roof fans and fans with, for this purpose, corresponding IP class). If the fans are installed without insulation in non-heated areas there is a risk of condensation. Safety accessories (i.e. motor protection, safety grille) may not be dismantled, short cut or disconnected. CAUTION! Before service or maintenance, switch off power, (all-pole circuit breaker), and make sure the impeller has come a standstill. CAUTION! The fans can have sharp edges and corners which may cause injuries. CAUTION! Be careful when opening the fans service-hatches (swing-out), the fan and motor assembled on the hatch is relatively heavy.

This appliance may be used by children under 8 years of age and older and persons with reduced physical, sensory or mental abilities or lack of experience and knowledge when supervised or instructed to use the appliance in a safe way and understand the potential hazards. Children should not play with the appliance. Cleaning and maintenance performed by the user must not be carried out by children without supervision.

#### Transportation and Storage

All fans are packaged at the factory to withstand normal transport handling. When handling the goods use suitable lifting equipment in order to avoid damage to fans and personnel. Do not lift the fans by the connecting cable, connection box, impeller or inlet cone. Avoid blows and shock loads. Store the fans in a dry place protected from weather and dirt until final installation.

#### Operation

*Before initial operation, check the following:*

- Electrical connection has been properly completed.
- Protective conductor has been connected.
- Motor protection installed.
- Safety devices in place (protection grid)

Leftover installation materials and foreign materials have been removed from the casing.

*When putting into operation, check the following:*

- Connection data corresponds to the specifications on the nameplate: Maximum voltage +6%, -10%, according to IEC38.

Rated current must not be exceeded with more than 5% at rated voltage. CAUTION! When the speed is regulating by reducing the voltage the motor current may exceed the rated current at a lower voltage. In this case the motor windings are protected by the thermal contact. The minimum static fall of pressure must be observed.

- The direction of rotation should correspond to direction-of rotation arrow.
- Smoothness of motor operation (no abnormal noises).
- Fans must only be operated by a person that has sustainable knowledge or education within this field or handling must be carried out with the supervision of such person.

#### Maintenance, Service and Repair

*Before maintenance, service or repairs make sure that:*

- Power supply is interrupted (all-pole circuit breaker).
- Fan impeller has come to a complete standstill
- Observe personnel safety regulations!

The fan should be cleaned when necessary, at least once per year to avoid imbalance and unnecessary damage to the bearings. A filter will prolong the time interval between each cleaning of the fan. (It is sometimes recommended to install a filter guard). The fan bearings are maintenance free and should only be replaced if damaged. Do not use a high-pressure cleaner (steam jet) when cleaning the fan. Make sure the fan impeller's balance weights are not moved or the fan impeller distorted. Listen for abnormal operating noise.

**Manufacturer**

PRIMA KLIMA TRADING CZ, s.r.o.  
 Zámostí 594, 33828 Radnice u Rokycan, Czech Republic  
 Phone: +420 371 795 340, Fax: +420 371 795 343,  
 Email: sales@primaklima.com, [www.primaklima.com](http://www.primaklima.com)

**Connection Scheme:**

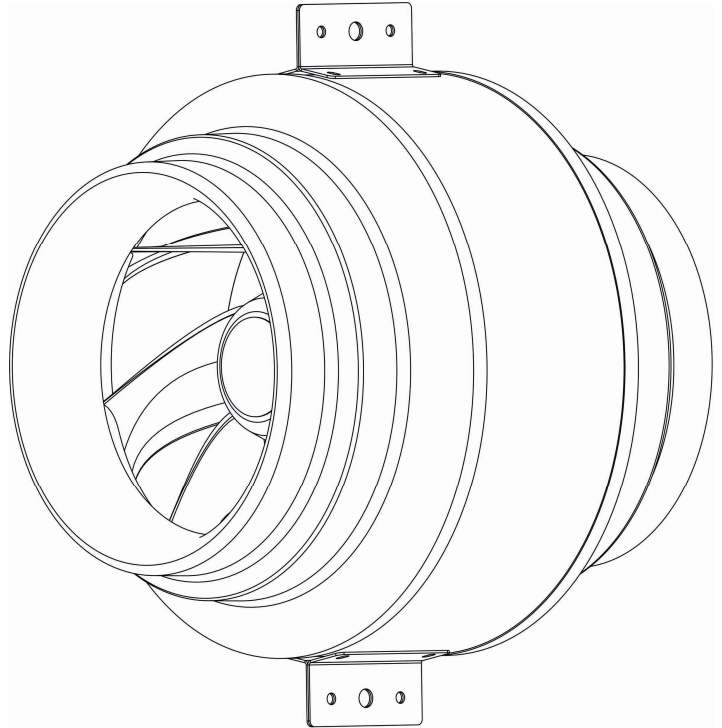
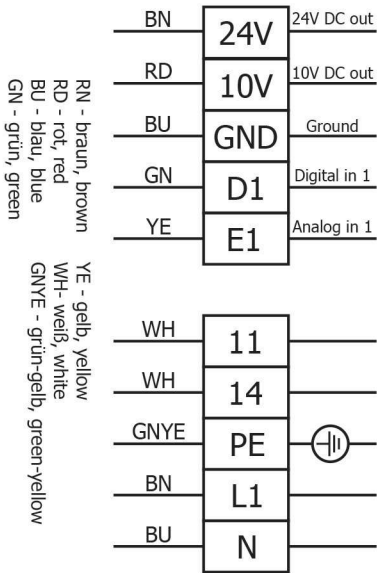

**PK355/400-EC ZIEHL-ABEGG Motor information's:**

